

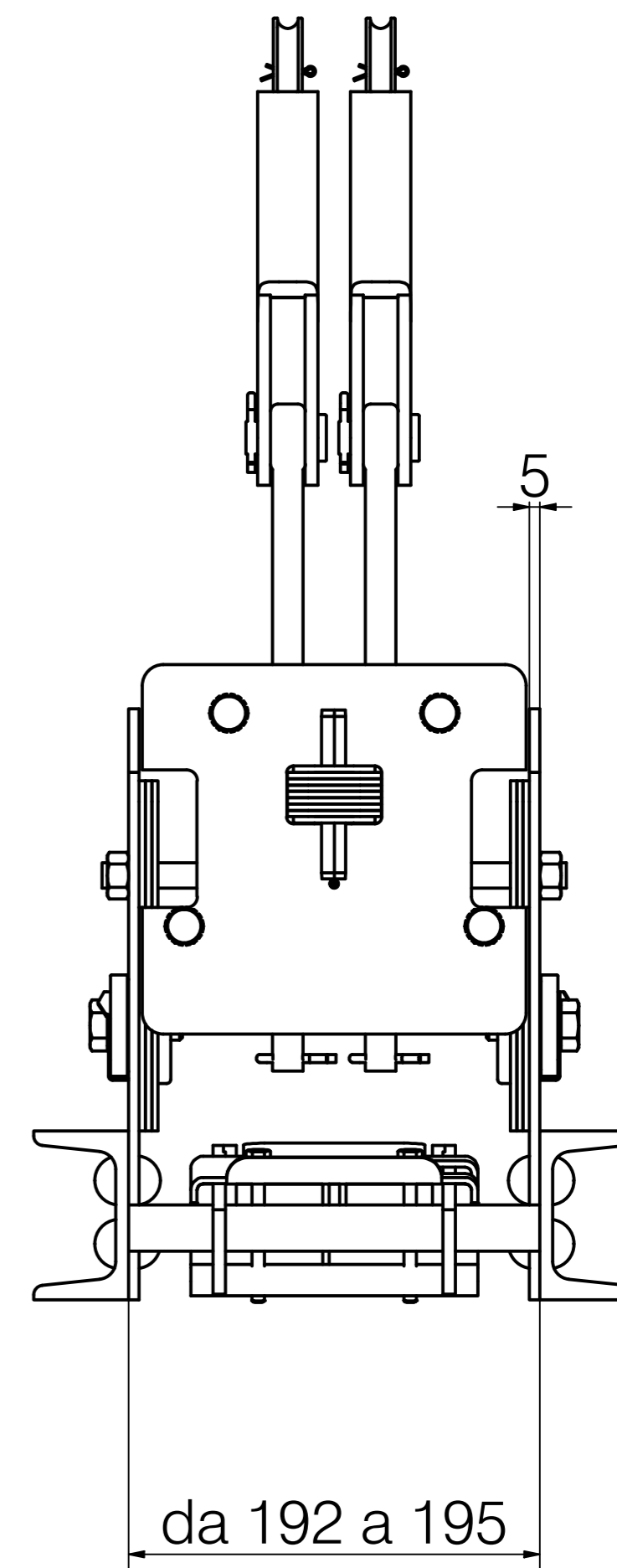

In fase di ordine o preventivo controllare sempre tutte le misure indicate

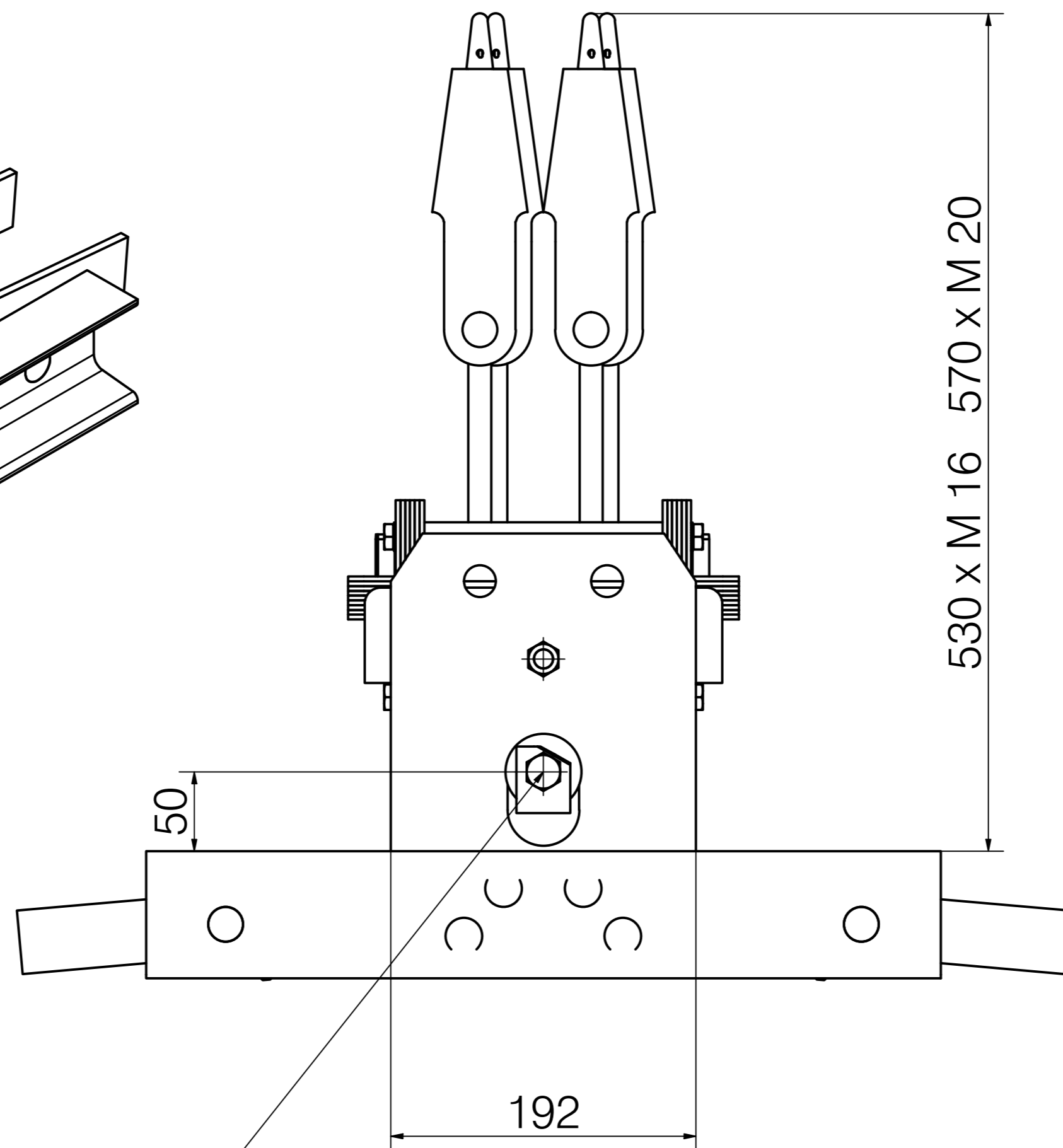
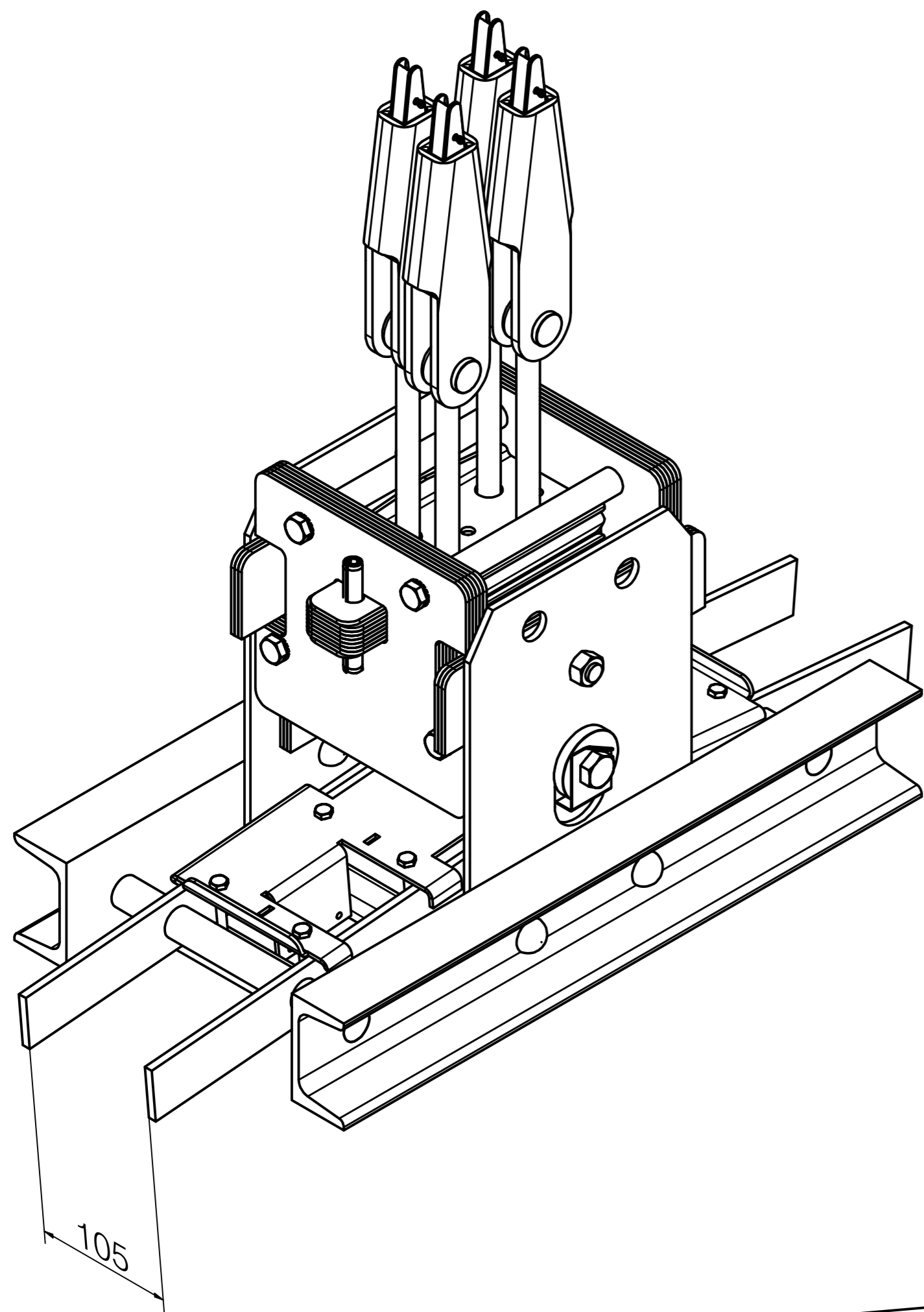

Perno diametro 45

Denominazione		Scala	
Ingombro sost. teste fuse Stigler Otis a bilanciere d. 45		1 : 3	
Data		Disegno N°	
07-06-24		83909	
 Dolzago Lecco Italy			