

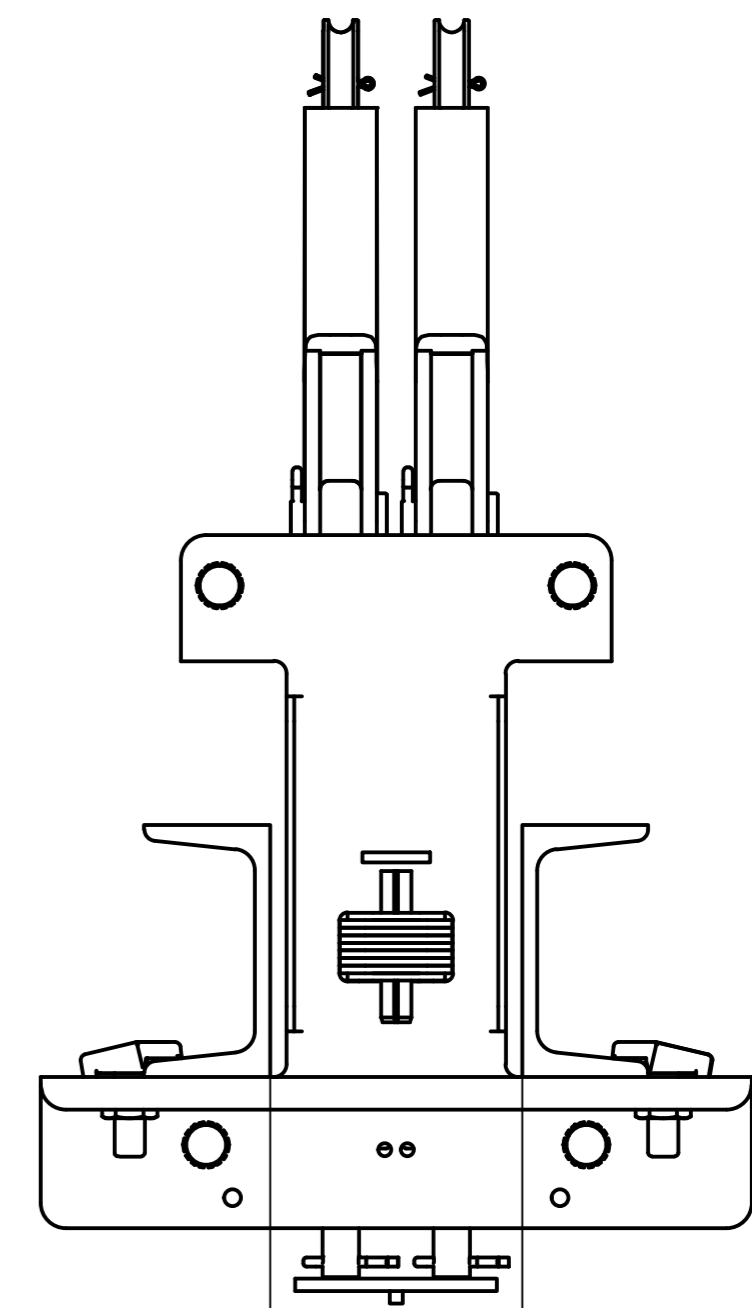

In fase di ordine o preventivo controllare sempre le misure indicate

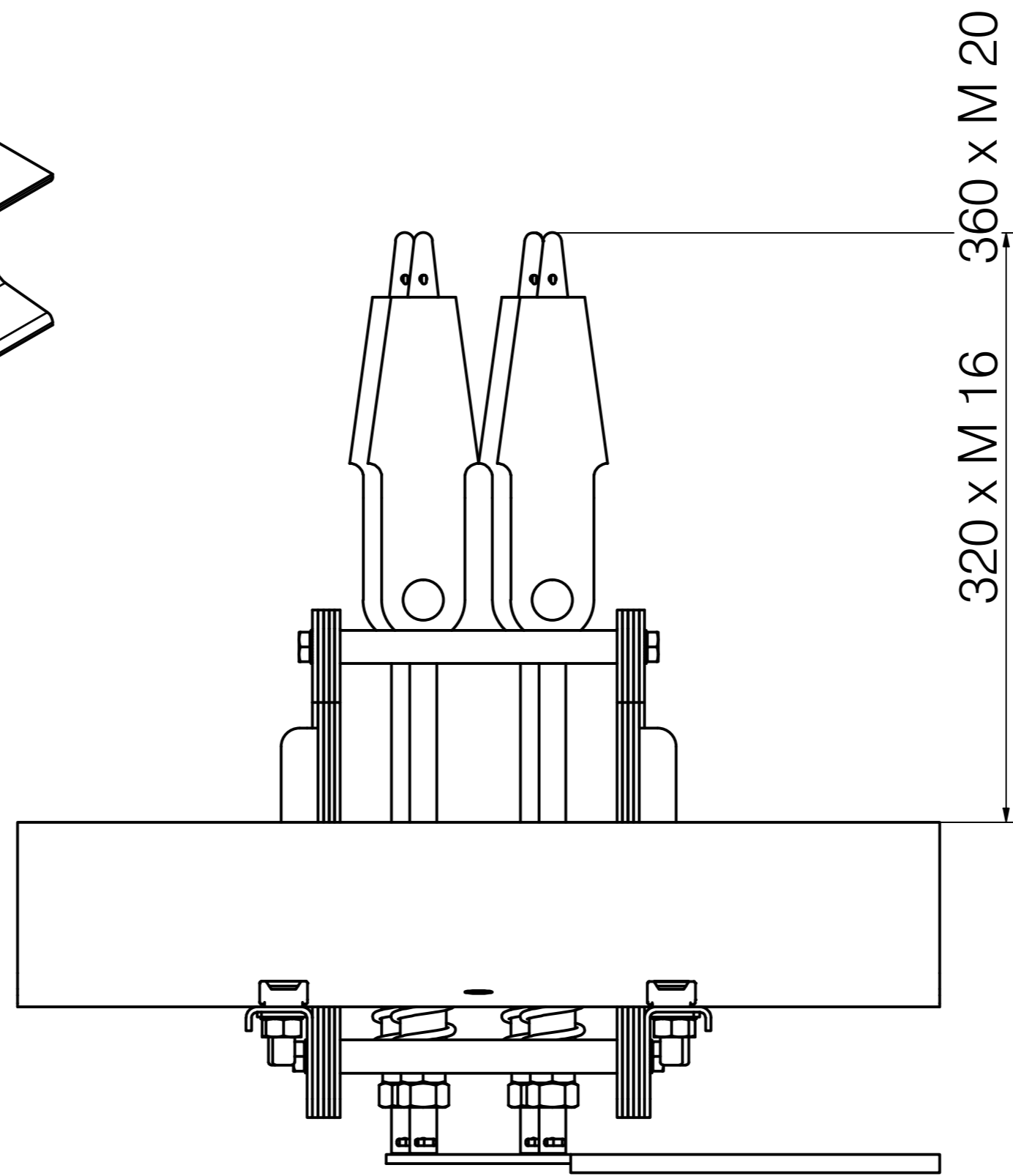
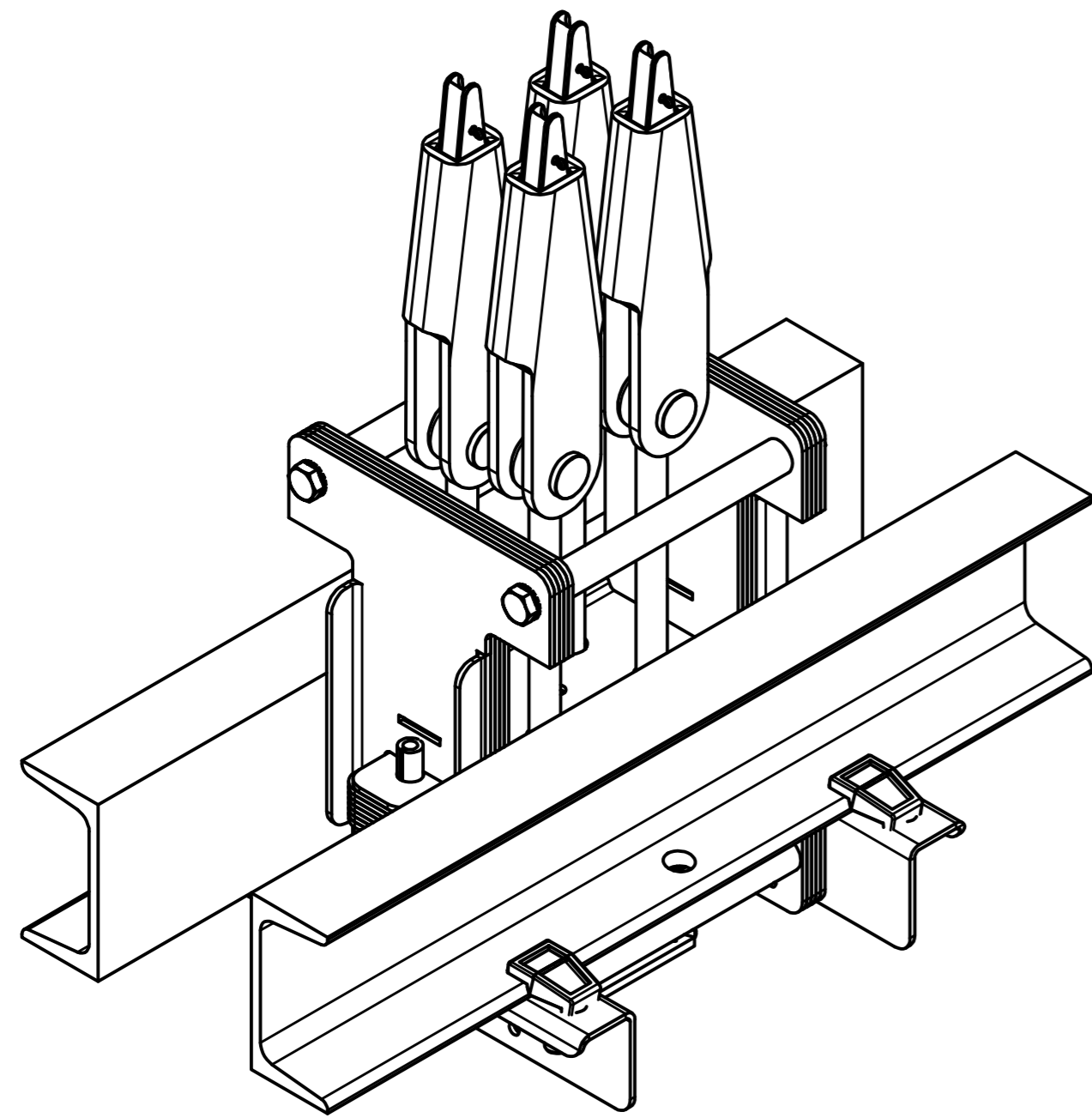

indicare la misura che deve essere inclusa tra 90 e 190

Denominazione		Scala	
Ingombro sostituzione teste fuse arcate SABIEM		1 : 2	
 Dolzago Lecco Italy	Data	Disegno N°	
	29-03-24	83786	